

CONVENTIONAL 2 ZONE FIRE ALARM PANEL

MODEL NO-AP CODE- C-2 Z

This microcontroller-based conventional fire alarm panel is designed to monitor and control Two independent fire detection zones, providing reliable and accurate fire event management. The system continuously supervises zone conditions and clearly displays their status through LCD and LED indicators.

In the event of Fire, Fault, or Short Circuit, the panel immediately identifies and indicates the affected zone. It also automatically performs the required actions, such as **activating the common hooter**, ensuring prompt alert and response.

Built using latest-generation technology, this fire alarm panel offers high reliability, stable performance, and user-friendly operation. It is specifically designed for small commercial buildings and small-scale industrial applications, where effective fire detection and quick notification are critical.

KEY FEATURES :

- As Per IS-15908:2011 Standard.
- 16x2 Dot Matrix LCD Display.
- Distinct indication for Fire, Fault, and Short Circuit conditions.
- Short Circuit/Overload Protection.
- Potential Free Contact Facility.
- Auto Dialer Integration Facility.
- Zone Healthy Indication.
- RS 485 Communication for Repeater Panel.
- Compatible With all Make Conventional Sensors.
- Relay Output for Actuators, For Fire & Fault.
- Lamp Test Facility.
- User Friendly Keypad for easy panel operation.
- Zone Isolation Facility with Zone Voltage Cutoff.
- Low Battery Visual Warning.
- Evacuate Switch for Emergency.
- Zone Name Editing Facility.
- Inbuilt Battery Charger & Battery Space. (2 Battery 12V 7Ah)
- B Class Wiring.





TECHNICAL SPECIFICATION:

Mains Voltage	220~230V AC
Frequency	50~60 Hz
Power Consumption	5 Watt/45 Watt (Normal/Fire)
Operating Voltage	24 V DC
Detection O/P Supply	24 V DC
Hooter O/P Supply	24 V DC
No of Relays	4

ALL ZONES ARE CLASS B WIRING

INITIATING DEVICE CIRCUITS (ZONE CERCUIT):

Normal Operating Voltage	16-24 V DC
Alarm Current	15-30mA
Short Circuit Current	100 mA
Maximum Zone Resistance	220 ohms
End of Line	4.7k
Standby Current	200 mA

ENVIRONMENTAL INFORMATION:

Operating Temperature	0° C to + 65° C
Operating Humidity	5 to 95% Relative Humidity (non- condensing)

MECHANICAL SPECIFICATION:

Cabinet Type	CRCA With Powder Coated Finish
Colour	Off White/Black/Red
Knock- Out	20mm
Dimension (WXHxD)	325 X261X103 mm
Weight without Batter	2.5 Kg (No Battery Fitted)

WIRING DIAGRAM:

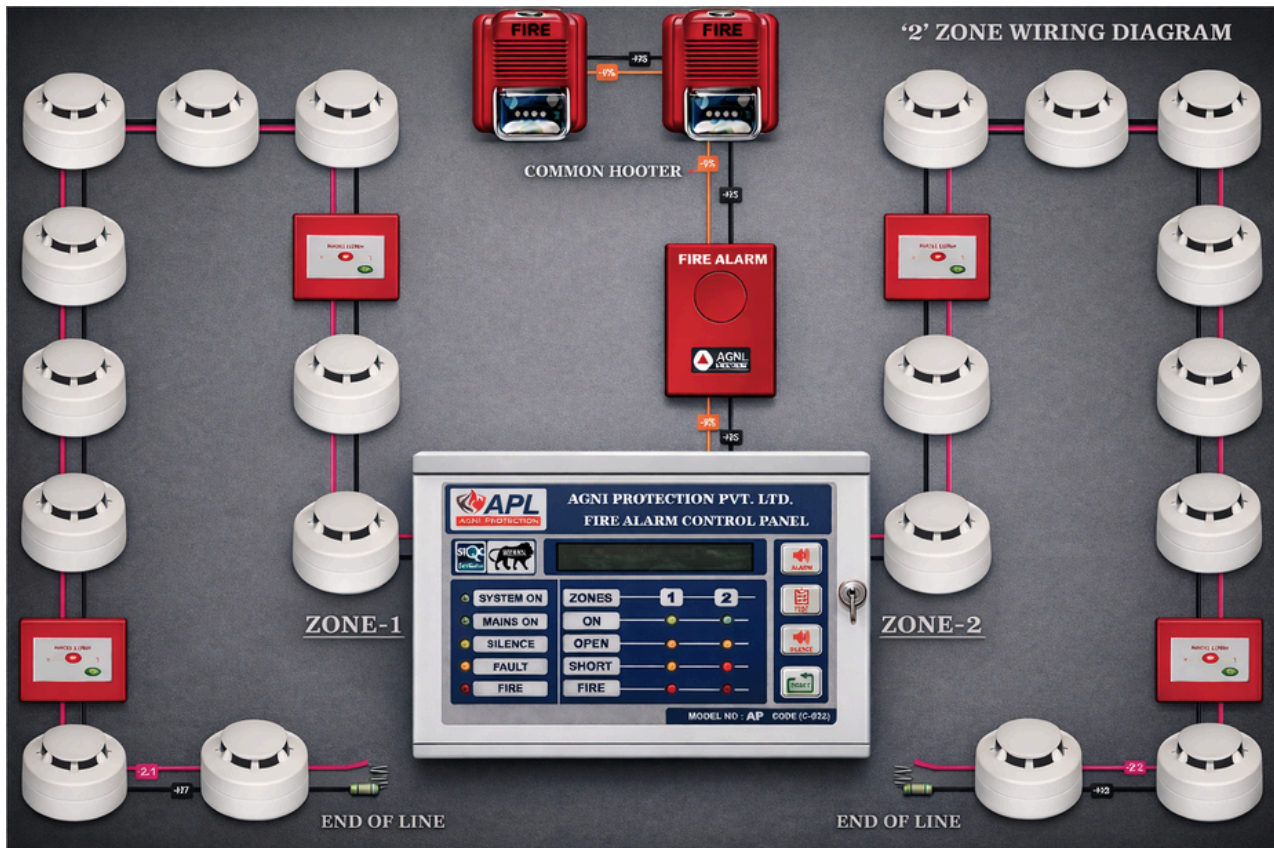

CONNECTION DIAGRAM:

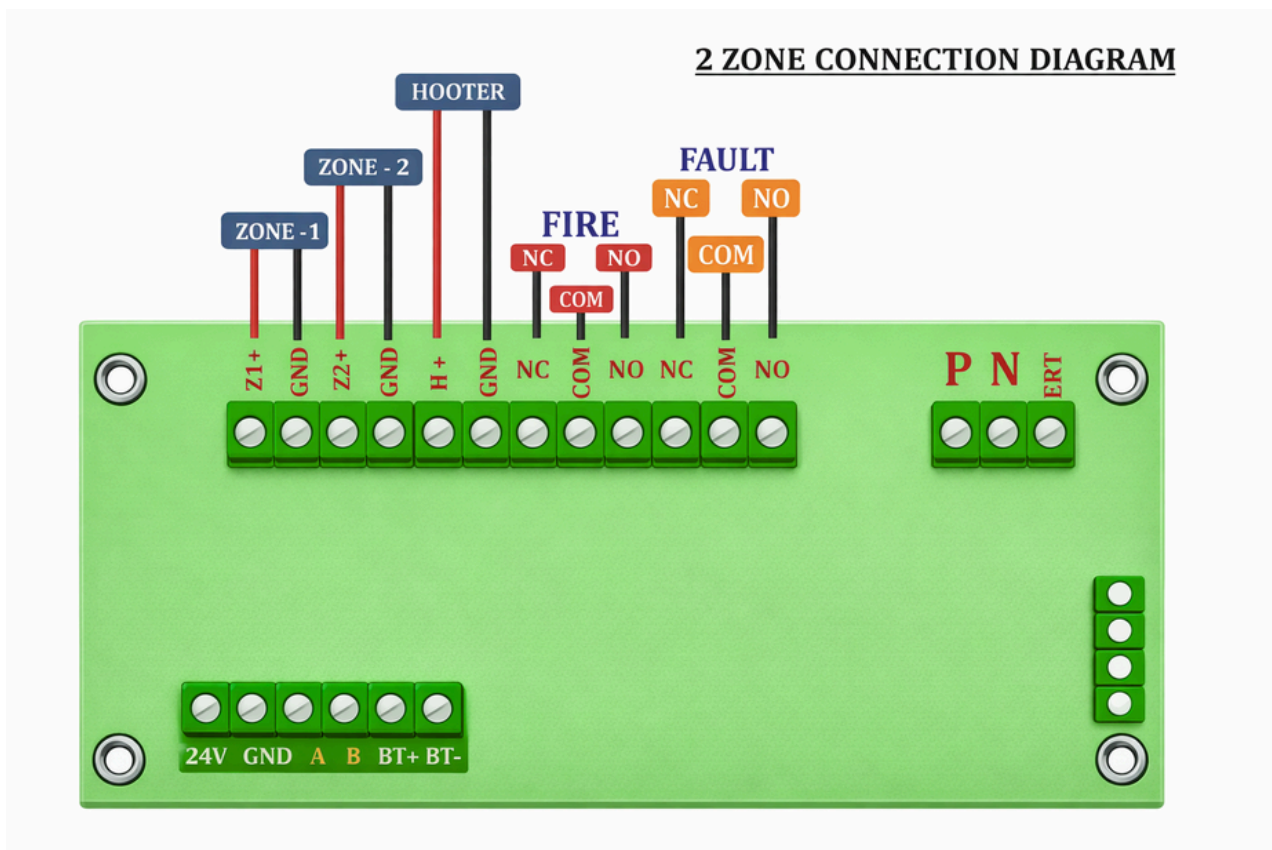



ORDERING INFORMATION:

CODE NO	PACK QTY.	DIMESION (WXHxD) MM	WEIGHT
C-2 Z	1	325X261X103	2.5 KG

APPROVED BY:

